

Models PD750, PD751, PD752 Universal Temperature Meters Instruction Manual



PD750
AC Powered
Units Only

- J, K, T, E, R, and S Thermocouples
- 100 Ω Platinum RTD
- 10 Ω Copper RTD
- 120 Ω Nickel RTD
- Displays $^{\circ}$ F or $^{\circ}$ C
- Factory Calibrated for All Inputs
- Type T T/C and RTDs Displayed to 0.1 $^{\circ}$
- NEMA 4X, IP65 Front Panel
- 115 VAC, 230 VAC, or 24 VDC Power Options
- 2 or 4 Relays + 4-20 mA Output Option

PRECISION DIGITAL CORPORATION
89 October Hill Road • Holliston MA 01746 USA
Tel (800) 610-5239 • Fax (508) 655-8990



www.predig.com

TABLE OF CONTENTS

| | |
|--|----|
| SPECIFICATIONS | 4 |
| OPTIONS | 5 |
| SETUP | 6 |
| POWER and SIGNAL CONNECTIONS | 6 |
| PROGRAMMING | 8 |
| CALIBRATION FLOW CHART | 9 |
| CALIBRATION (<i>CL ib</i>) | 10 |
| INPUT TYPE (<i>TYPE</i>) | 11 |
| SCALE (<i>F or C</i>) | 12 |
| 4 ALARM POINTS (<i>AL AR 5</i>) | 13 |
| FAIL-SAFE OPERATION | 15 |
| RELAYS (Optional) | 16 |
| SWITCHING INDUCTIVE LOADS | 17 |
| ISOLATED 4-20 mA OUTPUT OPTION (<i>OUTPUT</i>) | 18 |
| LOCKOUT | 20 |
| MOUNTING DIMENSIONS | 20 |
| OPTION CARD INSTALLATION | 21 |
| OTHER PRECISION DIGITAL PRODUCTS | 23 |

DEFINITIONS

TYPE, INPUT TYPE: To program unit for input type, (i.e. T/C or RTD).

F or C, Fahrenheit or Celsius: To program unit for Fahrenheit or Celsius display.

CL ib, CALIBRATION: To re-calibrate unit using a calibrated signal source.

AL AR 5, ALARM and RELAY POINTS: Sets alarm and relay set and reset points.

OUTPUT, 4-20 mA OUTPUT OPTION: Programs optional 4-20 mA output values.

Error, ERROR: Calibration not successful.

OPEN, OPEN T/C: Open thermocouple circuit indicated by flashing display.



WARNING

Hazardous voltages exist within enclosure.

Installation and service should be performed only by trained service personnel.



AVERTISSEMENT

Les pièces à l'intérieur du boîtier portent des tensions dangereuses. Seules des personnes qualifiées et bien entraînées devraient entreprendre l'étalonnage et la maintenance.

Notice

The information contained in this document is subject to change without notice.



ORDERING INFORMATION

Type J, K, T, E, R, S, and 100 Platinum RTD :

| 115 VAC Model | 230 VAC Model | 24 VDC Model | Options Installed | Option Card* |
|---------------|---------------|--------------|---------------------------|--------------|
| PD750-3-N | PD750-4-N | PD750-2-N | No Options | |
| PD750-3-14 | PD750-4-14 | PD750-2-14 | 2 Relays | PD174 |
| PD750-3-15 | PD750-4-15 | PD750-2-15 | 4-20mA Out | PD175 |
| PD750-3-16 | PD750-4-16 | PD750-2-16 | 2 Relays + 4-20 mA Out | PD176 |
| PD750-3-17 | PD750-4-17 | PD750-2-17 | 4 Relays | PD177 |
| PD750-3-18 | PD750-4-18 | PD750-2-18 | 4 Relays + 4-20 mA Out | PD178 |

10 Copper

| 115 VAC Model | 230 VAC Model | 24 VDC Model | Options Installed | Option Card* |
|---------------|---------------|--------------|---------------------------|--------------|
| PD751-3-N | PD751-4-N | PD751-2-N | No Options | |
| PD751-3-14 | PD751-4-14 | PD751-2-14 | 2 Relays | PD174 |
| PD751-3-15 | PD751-4-15 | PD751-2-15 | 4-20mA Out | PD175 |
| PD751-3-16 | PD751-4-16 | PD751-2-16 | 2 Relays + 4-20 mA Out | PD176 |
| PD751-3-17 | PD751-4-17 | PD751-2-17 | 4 Relays | PD177 |
| PD751-3-18 | PD751-4-18 | PD751-2-18 | 4 Relays + 4-20 mA Out | PD178 |

120 Nickel

| 115 VAC Model | 230 VAC Model | 24 VDC Model | Options Installed | Option Card* |
|---------------|---------------|--------------|---------------------------|--------------|
| PD752-3-N | PD752-4-N | PD752-2-N | No Options | |
| PD752-3-14 | PD752-4-14 | PD752-2-14 | 2 Relays | PD174 |
| PD752-3-15 | PD752-4-15 | PD752-2-15 | 4-20mA Out | PD175 |
| PD752-3-16 | PD752-4-16 | PD752-2-16 | 2 Relays + 4-20 mA Out | PD176 |
| PD752-3-17 | PD752-4-17 | PD752-2-17 | 4 Relays | PD177 |
| PD752-3-18 | PD752-4-18 | PD752-2-18 | 4 Relays + 4-20 mA Out | PD178 |

Ordering example: PD750-3-14, temperature meter powered from
115 VAC (-3) with 2 relays (-14).

SPECIFICATIONS

Basic Meter

INPUTS: PD750: Field selectable: type J, K, T, E, R, or S Thermocouples with 1° resolution; type T to 0.1° 100 platinum RTD (.00385 or .00392 curve) to 1° or 0.1° resolution.

PD751: 10 copper RTD

PD752: 120 nickel RTD

DISPLAY: Bright, large, 0.56" (14.2mm) high efficiency red, 4¹/₂ digits. F or C may be switched on to indicate Fahrenheit or Celsius.

COLD JUNCTION REFERENCE: Automatic, fixed, no user calibration needed.

SENSOR BREAK DETECTION: Open sensor circuit indicated by display flashing $\overline{bPE}n$. All relays and alarm status LEDs go to alarm state.

HOLD READING: Connect switch to ACK/HLD and COM terminals, also connect jumper pins on rear.

ACCURACY: See Thermocouple and RTD chart, page 11.

LOCKOUT: Jumper JP2 at rear of instrument restricts modification of calibration values.

INPUT IMPEDANCE: Greater than 100 K .

POWER: AC power: 115 VAC \pm 10%, 50/60 Hz, 10 VA.

230 VAC \pm 10%, 50/60 Hz, 10 VA.

DC power: 22-28 VDC, 6 watts max.

ISOLATION: AC power: 1500 VAC; DC power: 500 VDC.

NORMAL MODE REJECTION: 64 dB at 50/60 Hz

ENVIRONMENTAL: Operational ambient temperature range: 0 to +60°C. Storage temperature range: -40 to +85°C. Relative humidity: 0 to 90% non-condensing.

ENCLOSURE: 1/8 DIN, high impact plastic, UL 94V-0.

FRONT PANEL: NEMA 4X, IP65, panel gasket provided.

WEIGHT: 19.7 oz (559 g) (including options)

CONNECTIONS: Removable screw terminal block, accepts #22 to #12 AWG.

ALARM POINTS: 4, any combination of high or low alarms.

ALARM STATUS INDICATION: Front panel LED

ALARM DEADBAND: 0-100% of full scale, user selectable.

UL FILE NUMBER: E160849; 508 Industrial Control Equipment
(PD750 AC Powered Unit only)

OPTIONS

Relays

RATING: 2 or 4 SPDT (form C); rated 2 Amp @ 30 VDC or 2 Amp @ 250 VAC resistive load; 1/14 HP @ 125 / 250 VAC for inductive loads.

RESET: User select.

1. Automatically when the input passes the reset point.
2. Automatically + manually (via user supplied switch or front panel ACK button). Manual reset resets all manually resettable relays.

FAIL-SAFE OPERATION: The relay coils are energized in the non-alarm condition. In the case of a power failure, the relays will go to the alarm state. Fail-safe operation by removing jumper J2 located on the Options Board.

AUTO INITIALIZATION: When power is applied to the meter, the relays will always reflect the state of the input to the meter.

DEADBAND: 0-100%, User selectable.

Isolated 4-20 mA Transmitter Output

CALIBRATION RANGE: The transmitter output can be calibrated so that a 4 mA output is produced for any number displayed on the meter. The 20 mA output may correspond to any number displayed on the meter above or below the 4 mA output display.

OUTPUT LOOP RESISTANCE:

| Power supply: | minimum | maximum |
|-------------------|---------|---------|
| 24 VDC | 10 | 600 |
| 35 VDC (external) | 600 | 1000 |

ACCURACY: $\pm 0.1\%$ F.S., $\pm .004$ mA.

ISOLATION: 500 VDC or peak AC, input-to-output or input/output-to-power line.

EXTERNAL LOOP POWER SUPPLY: 35 V max.

WARRANTY:

2 years parts & labor

EXTENDED WARRANTY:

1 or 2 years, refer to the Price List for details.

SETUP

Programming and installing the meter involves six basic steps.

- Step 1 Remove jumper JP2 if installed, to disable the lockout feature.
- Step 2 Configure the input signal jumper JP1 according to the input type, thermocouple or RTD, see charts below.
- Step 3 Connect the input signal according to the chart below.
- Step 4 Connect power.
- Step 5 Program the input type, choice 0-10, see page 11.
- Step 6 Program the scale type, Fahrenheit or Celsius, see page 12.

POWER and SIGNAL CONNECTIONS

24 V Transmitter power: P+, P-

For DC powered units see diagrams on page 7

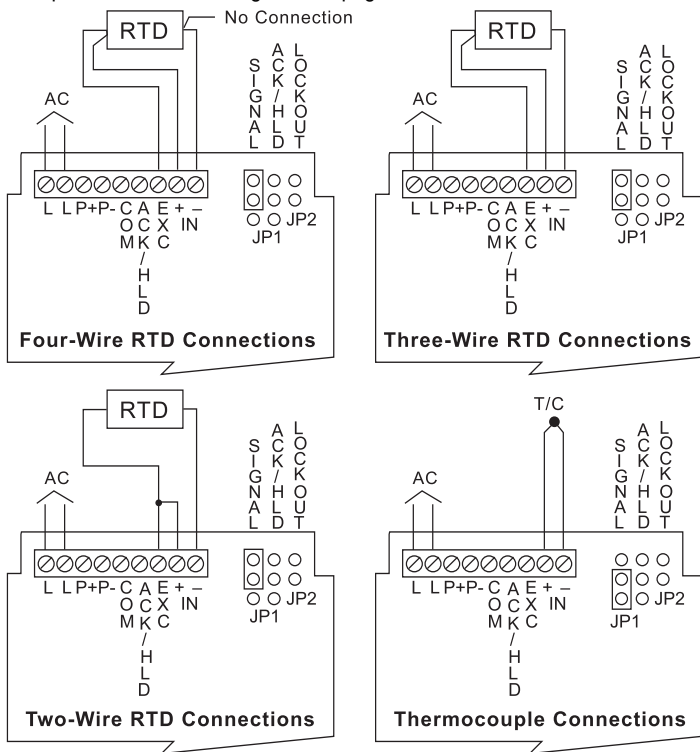

POWER and SIGNAL CONNECTIONS for DC POWERED UNITS

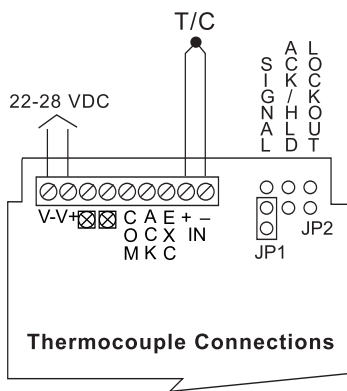
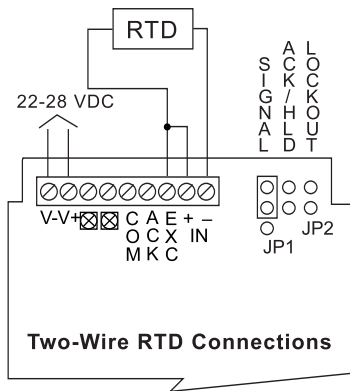
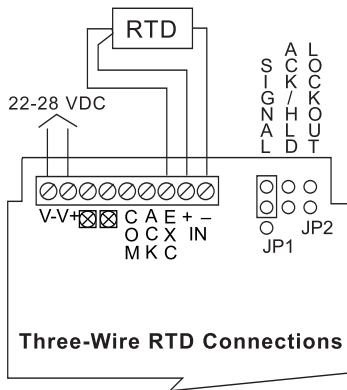
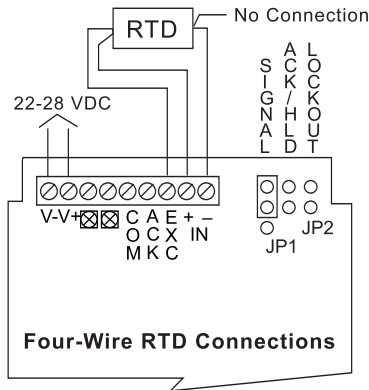

WIRING INSTRUCTIONS

- All field connections to be made with either solid or stranded insulated wire. Strip length = 1/4" (7 mm). Tighten screw terminals to 4.5 lb-in (0.5 Nm). Do not pre-treat wire with solder.
- Terminals connected to line voltage (e.g. L, RELAY 1-4): Use AWG # 12-18 copper wire, 600 volt, 60°C or 60/75°C. Connect only one wire to each terminal.
- Terminals not connected to line voltage (e.g. IN, EXC, ACK, COM, P+, P-, V+, V-, +, -): Use AWG #12-22 wire. If using AWG #20 or smaller wire, up to two wires may be connected to each terminal. If using AWG #18 or larger wire, only one wire may be connected to each terminal.



PROGRAMMING

The meter's **Single Button Scaling** feature allows it to be programmed using only the **ENTER** button. The general procedure is to press the **ENTER** button to accept a flashing display or to wait for the display to scroll and press **ENTER** when the desired display appears.

For instance when the **ENTER** button is pressed, the meter scrolls through the standard programming routine titles: *CAL Ib*, *TYPE, F or C*, *ALARMS*. It will also scroll the optional programming routine title: *OUTPut* if the meter contains the isolated 4-20 mA Output Option. To enter a programming routine, press **ENTER** when the meter displays the desired programming routine title.

The following flow chart overviews the meter programming routines.

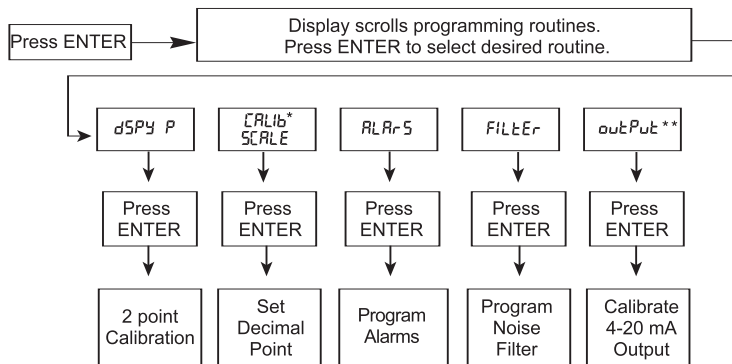

There are 5 basic programming instructions

1. If the flashing display is OK, press **ENTER** before it stops flashing to accept it.
2. If the flashing display is not OK, (or if **ENTER** was not pressed in time to accept it), wait for first digit to flash.
3. If a flashing digit is OK press **ENTER** before it starts to scroll to accept it.
4. If a flashing digit is not OK, (or if **ENTER** was not pressed in time to accept it), wait for the digit to scroll, and press **ENTER** when OK.
5. Digits will scroll until **ENTER** is pressed. When a digit is accepted by pressing **ENTER**, the next digit flashes.

For best results, allow the meter to warm up for at least 30 minutes before calibrating.

CALIBRATION FLOW CHART

The following flow chart illustrates a 2 point calibration using **Single Button Scaling**. The same general procedure is used for alarm set and reset point programming and 4-20 mA output programming.

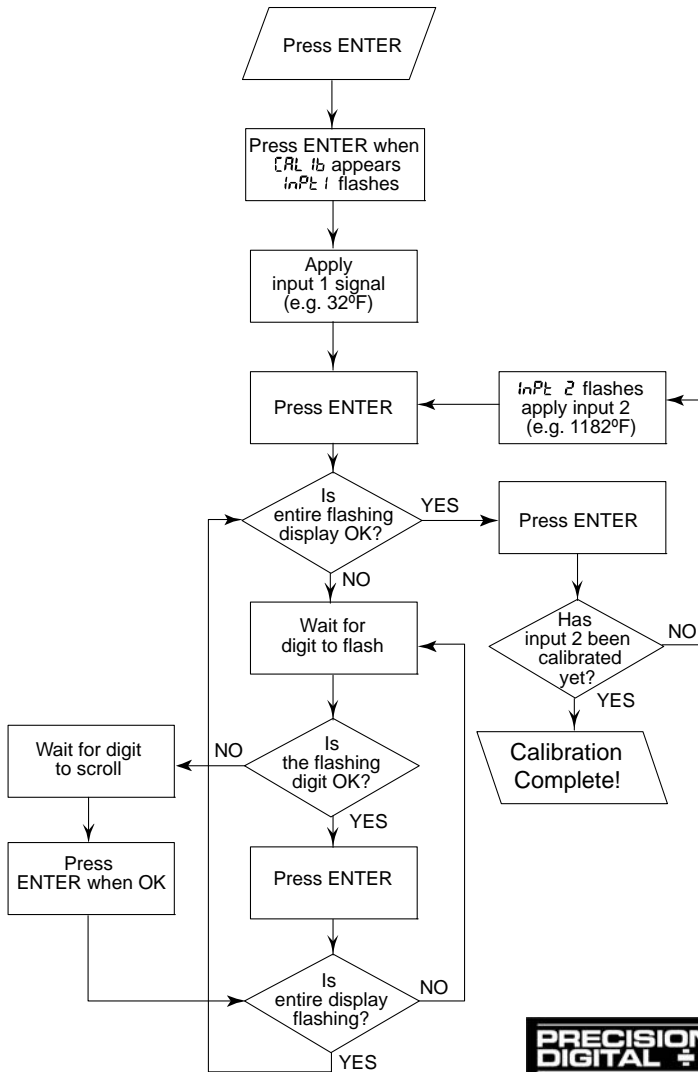

CALIBRATION (CAL Ib)

The PD750 is pre-calibrated for 6 types of thermocouples and 2 types of 100 RTD sensors. The PD751 is pre-calibrated for 10 copper RTD sensors and the PD752 is pre-calibrated for 120 nickel RTD sensors.

These input ranges may be re-calibrated and should be checked every 12 months. Calibration is performed from the front panel using the **ENTER** button. It does not require any tools or disassembly of the meter. The only equipment needed is a thermocouple calibrator or a 5 decade resistance box with an accuracy of about 0.1% and a minimum resistance of 0.01 for RTDs.

Go to **INPUT TYPE** on page 11 if calibration is not necessary.

Input 1 Calibration

1. Press **ENTER**, when **CAL Ib** appears press **ENTER** again.
2. Meter flashes **InPt 1**. Apply input 1 (low signal) using a calibrator, THEN press **ENTER**.
3. All digits flash for 3 seconds.

If this is the desired display for input 1, press **ENTER** before entire display stops flashing, (meter will then flash **InPt 2**). Go to step 9 below.

If this is not the desired display, (or if **ENTER** was not pressed in time to accept the display) wait for the first digit to flash.

First digit flashes for 3 seconds before it scrolls.

4. When digit is OK, press **ENTER**, next digit will flash for 3 seconds before it scrolls.
5. When flashing digit is OK, press **ENTER**, next digit will flash for 3 seconds before it scrolls.
6. Repeat step 4 for each remaining digits.
7. When last digit is OK, press **ENTER**.
8. Entire display will flash for 3 seconds. Press **ENTER** within the 3 seconds if OK to complete input 1 calibration. If not OK, wait for first digit to flash and go to step 3 above.
9. Meter flashes **InPt 2**. Apply input 2 (high signal) using a calibrator, THEN press **ENTER**.
10. GO TO STEP 3 ABOVE.

Calibration Error

An **Error** message during calibration indicates that the calibration process was not successful. The meter should be recalibrated.

An **Error** message will appear if input 1 and input 2 signals are within 4 millivolts.

An **Error** message will appear if input 1 signal is inadvertently also applied for input 2 calibration, or **ENTER** is pressed before applying input 2.

INPUT TYPE (TYPE)

The meter must be programmed for the input type it is to accept. Selecting the wrong input type will cause an incorrect temperature to be displayed.

Selecting Input Type

1. Press **ENTER**. When **TYPE** appears, press **ENTER** again.
2. The meter displays **TYPE** and starts to scroll through make it choice. Press **ENTER** when desired digit appears, (see chart below). Meter will then reset back to indication mode.

PD750 Input Ranges

| Type Number | Type of Input | Range | Accuracy |
|-------------|----------------------------|---|------------------|
| 0 | Type J T/C | -328° to 1382°F -200° to 750°C | ±2°F ±1°C |
| 1 | Type K T/C | -328° to 2498°F -200° to 1330°C | ±2°F ±1°C |
| 2 | Type T T/C | -330° to 760°F -200° to 404°C | ±2°F ±1°C |
| 3 | Type T T/C (0.1°) | -330.0° to 760.0°F -200.0° to 404.0°C | ±2°F ±1°C |
| 4 | Type E T/C | -328° to 1832°F -200° to 1000°C | ±2°F ±1°C |
| 5 | Type R T/C | 32° to 3213°F 0° to 1767°C | ±5°F ±3°C |
| 6 | Type S T/C | 40° to 3214°F 4° to 1768°C | ±6°F ±3°C |
| 7 | 100 RTD (0.00385, 0.1°) | -328.0° to 1382.0°F -200.0° to 750.0°C | ±0.7°F ±0.4°C |
| 8 | 100 RTD (0.00392, 0.1°) | -328.0° to 1382.0°F -200.0° to 750.0°C | ±0.7°F ±0.4°C |
| 9 | 100 RTD (0.00385, 1°) | -328° to 1382°F -200° to 750°C | ±1°F ±1°C |
| 10 | 100 RTD (0.00392, 1°) | -328° to 1382°F -200° to 750°C | ±1°F ±1°C |

PD751 Input Ranges

| Type Number | Type of Input/ Resolution | Range | Accuracy |
|-------------|---------------------------|--|------------------|
| 0 | 10 Cu 0.1 degree | -328.0° to 500.0°F -200.0° to 260.0°C | ±0.2°F ±0.1°C |
| 1 | 10 Cu 1 degree | -328° to 500°F -200° to 260°C | ±0.2°F ±0.1°C |

PD752 Input Ranges

| Type Number | Type of Input/ Resolution | Range | Accuracy |
|-------------|---------------------------|---|------------------|
| 2 | 120 Ni 0.1 degree | -112.0° to 608.0°F -80.0° to 320.0°C | ±0.2°F ±0.1°C |
| 3 | 120 Ni 1 degree | -112° to 608°F -80° to 320°C | ±0.2°F ±0.1°C |

RECOMMENDED CALIBRATION POINTS

| Type Number | Type of Input | Input 1 (Low) | Input 2 (High) | Check (Middle) |
|-------------|----------------------------|---------------|--------------------|-------------------|
| 0 | Type J T/C | 32°F | 1182°F | 600°F |
| 1 | Type K T/C | 32°F | 1183°F | 960°F |
| 2 | Type T T/C | 32°F | 693°F | 360°F |
| 3 | Type T T/C | 32.0°F | 693.0°F | 360.0°F |
| 4 | Type E T/C | 32°F | 1652°F | 840°F |
| 5 | Type R T/C | 100°F | 3000°F | 1500°F |
| 6 | Type S T/C | 100°F | 3000°F | 1500°F |
| 7 | 100 RTD (0.00385, 0.1°) | 32.0°F 100 | 1148.0°F 320.12 | 590.0°F 215.61 |
| 8 | 100 RTD (0.00392, 0.1°) | 32.0°F 100 | 1127.0°F 320.89 | 580.0°F 215.87 |
| 9 | 100 RTD (0.00385, 1°) | 32°F 100 | 1148°F 320.12 | 590°F 215.61 |
| 10 | 100 RTD (0.00392, 1°) | 32°F 100 | 1127°F 320.89 | 580°F 215.87 |

SCALE (F or C)

F or C may be switched on to indicate Fahrenheit or Celsius.

Selecting Fahrenheit or Celsius

1. Press **ENTER**, when *F or C* appears press **ENTER** again.
2. The meter will display *F or C* alternately. Press **ENTER** when desired character is flashing. Meter will then return to indication mode and display the temperature in either Fahrenheit or Celsius.

4 ALARM POINTS (ALARM-5)

The meter is equipped with 4 alarm points as a standard feature. Each alarm may be programmed for either a high or low alarm and for 0-100% deadband. Front panel LEDs indicate alarm status.

Options for 2 and 4 relays are available.

To program a high alarm, program the set point above the reset point. To program a low alarm, program the set point below the reset point.

To program the alarm deadband, set the reset point above or below the set point by an amount equal to the desired deadband value.

Example: Alarm 2 is a high alarm that trips at 1500° and has a deadband of 100°
Alarm 2 set point is set at 1500° and its reset point at 1400°

Alarm Set and Reset Point Programming (ALARM-5)

Alarm set and reset point programming is performed in the *ALARM-5* routine.

1. To enter the *ALARM-5* routine, press **ENTER** and when *ALARM-5* appears, press **ENTER** again. This starts a scan of the 4 alarm set and reset points.

The scan sequence begins with a flashing display of alarm #1 set point. The “1” LED and “S” LED are illuminated to indicate the meter is flashing alarm #1 set point value.

2. All digits flash for 3 seconds.

If this is the desired display for this alarm point, press **ENTER**. Pressing **ENTER** completes this alarm point programming. Proceed to step 8 for next alarm point programming.

If this is not the desired display, wait for the first digit to flash. It will flash for 3 seconds before it starts to scroll.

3. If the first flashing digit is OK, press **ENTER** before it starts to scroll to accept it, the next digit flashes- go to step 6. If not OK, wait for first digit to scroll.

4. When the first digit is OK, press **ENTER** and the next digit flashes for 3 seconds before it starts to scroll.

5. If the flashing digit is OK, press **ENTER** before it scrolls. If not OK, wait for digit to scroll.
6. When digit is OK, press **ENTER**. Program remaining digits in same fashion.
7. When the last digit is OK, press **ENTER**. The entire display flashes for 3 seconds. Press **ENTER** if OK to complete alarm point programming and proceed to step 8. If not OK, wait, first digit flashes. Repeat steps 3-7.
8. When an alarm set or reset point has been programmed the scan moves to the next alarm set or reset point. To program the remaining alarm set and reset points, repeat steps 2-8.

Determine which alarm set or reset point is being programmed by noting which LEDs are illuminated. For instance, if the "3" LED and the "R" LED are illuminated, the meter is displaying alarm #3 reset point. When alarm programming is complete the meter will display the process input signal and the front panel LEDs will indicate alarm status.

Programming Confirmation

To verify that the alarm set and reset points have been programmed as desired, press **ENTER**, and press **ENTER** again when *AL Rr S* appears. Before the display stops flashing #1 set point value, press **ENTER** again to advance the display to #1 reset point. Continue skipping through the remaining alarm set and reset points. To alter an alarm point value, wait for the first digit to flash and follow steps 3-8 above.

Alarm Operation

When the meter detects an alarm, a front panel LED illuminates to indicate which alarm point has been tripped. This LED will stay illuminated until the meter display passes through the reset point.

Alarm Acknowledgment

The ACK button on the front panel resets the optional relays only and has no effect on the alarm status LEDs.

FAIL-SAFE OPERATION:

The relay coils are energized in the non-alarm condition. In the case of a power failure, the relays will go to the alarm state. The fail-safe operation can be disabled by removing jumper J2 located at the front of the relay option card.

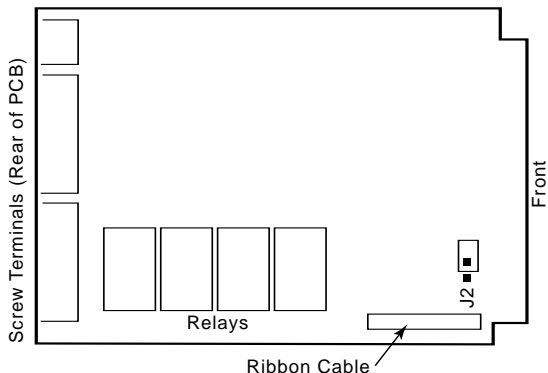
**OPTION CARD PIN-OUTS**

| | Pin: | Function: | | |
|----|------|-----------------|---------|---------|
| J1 | { 1 | Transmitter + |] PD175 |] PD178 |
| | { 2 | Transmitter - | | |
| J2 | { 1 | Relay #1 Common |] PD176 | |
| | { 2 | Relay #1 NC | | |
| | { 3 | Relay #1 NO |] PD174 | |
| | { 4 | Relay #2 Common | | |
| | { 5 | Relay #2 NC | | |
| | { 6 | Relay #2 NO | | |
| J3 | { 1 | Relay #3 Common |] PD177 | |
| | { 2 | Relay #3 NC | | |
| | { 3 | Relay #3 NO |] PD178 | |
| | { 4 | Relay #4 Common | | |
| | { 5 | Relay #4 NC | | |
| | { 6 | Relay #4 NO | | |

Notes:

1. Alarm acknowledgement terminals (ACK and COM) are located on the meter main board.
2. In the alarm condition, the NC contact is connected to common in the fail-safe mode.

RELAYS (Optional)

The meter is available with 2 and 4 relays. The SPDT relays can be programmed for automatic or automatic + manual reset. The relays can also be programmed for 0-100% deadband.

Set and Reset Point Programming

Refer to page 13 to program the alarm (relay) set and reset points.

Automatic and Manual Reset Programming

There are two ways to reset the relays:

1. Automatically when the signal passes through the reset point.
2. Automatically + manually via the front panel ACK button, or a user supplied switch across terminals at the rear of the instrument. That is, a relay may be manually reset prior to the signal passing through the reset point, or, if it is not, it will automatically reset when the signal passes through the reset point.

A manual reset will reset all relays that are programmed for automatic + manual reset.

An array of jumpers located behind the front panel on the Display Board is used to program each relay for either automatic or automatic + manual reset. Refer to page 21 for front panel removal instructions. The top jumper is used for relay 1, the next for relay 2, etc. A relay will automatically reset if no jumper is installed. A relay will automatically reset, plus can be manually reset, if a jumper is installed over its respective pins.

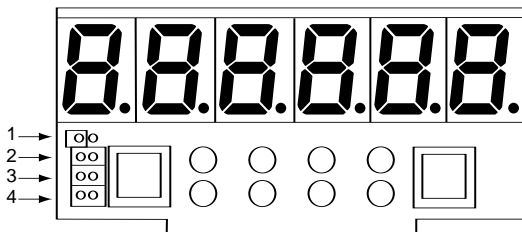

Jumpers to program relays for either automatic or automatic + manual reset.

Example: Relay 1 is programmed for automatic reset only.

Relays 2, 3, and 4 are programmed for automatic + manual reset.

SWITCHING INDUCTIVE LOADS

The meter has the ability to suppress electrical noise generated by switching inductive loads. However, installing suppressors improves this performance even more and prolongs the life of the meter's relay contacts.

This suppression can be obtained with RC networks assembled by the user or purchased as a complete assembly. Refer to the following circuits for RC network assembly and installation:

AC and DC LOADS

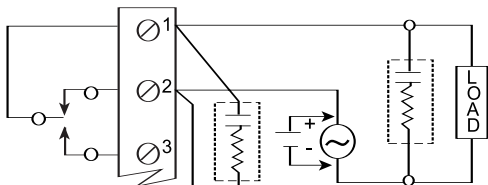

Choose R and C as follows

R: 0.5 to 1 Ω for each volt across the contacts

C: 0.5 to 1 μF for each 1 A through closed contacts

Notes

1. Use capacitors rated for 240 VAC.
2. Snubbers may affect load release time of solenoid loads, check to confirm proper operation.
3. Install the RC network right at the meter's relay screw terminals. An RC network may also be installed across the load.

LOW VOLTAGE DC LOADS

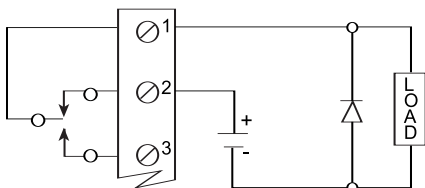

Use a diode with a reverse breakdown voltage two to three times the circuit voltage and forward current at least as large as the load current.

RC NETWORKS

Suppressors are available and should be applied to each relay that switches an inductive load. Part number PDX6901.

ISOLATED 4-20 mA OUTPUT OPTION (*output*)

The meter can be equipped with an isolated 4-20 mA output signal option that can be programmed to produce a 4-20 mA output for virtually any input.

Connections

The following drawings illustrate the 4-20 mA output signal being powered from the meter's internal 24 V power supply (AC powered units only) and by an external power supply.

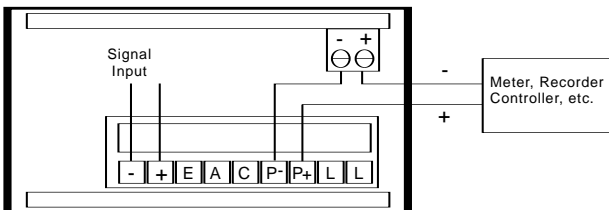

4-20 mA output signal being powered by meter's internal 24 V power supply.

AC powered units only

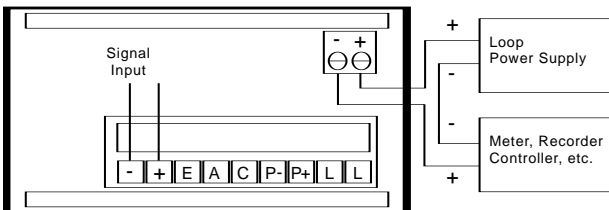

4-20 mA output signal being powered from an external 24 V power supply.

! If the output loop is powered by an external supply, the loop power supply must be turned on before the meter is turned on. Otherwise, the output loop signal may be incorrect.

Calibration

The isolated 4-20 mA output signal is calibrated using the front panel **ENTER** button and uses the same **Single Button Scaling** technique that is used to calibrate the signal input and the alarm set and reset points. A multimeter may be connected to the output terminals to verify calibration, but it is not required as part of the calibration process.

4 mA Output Calibration

1. Press **ENTER**, when **OutPut** appears press **ENTER** again.
2. All digits flash for 3 seconds, a green LED labeled "4" illuminates indicating the flashing display is the value at which the meter will produce a 4 mA output.

If this is the desired display at which the meter will produce a 4 mA output, press **ENTER** before entire display stops flashing. The meter indicates that the 4 mA Output Calibration is now complete by illuminating the green "20" LED. Go to 20 mA Output Calibration below.

If this is not the desired display, (or if **ENTER** was not pressed in time to accept the display) wait for the first digit to flash.

3. First digit flashes for 3 seconds before it scrolls.
4. When first digit is OK, press **ENTER**, next digit will flash for 3 seconds before it scrolls.
5. When flashing digit is OK, press **ENTER**, next digit will flash for 3 seconds before it scrolls.
6. Repeat step 5 for each remaining digits.
7. When last digit is OK, press **ENTER**.
8. Entire display will flash for 3 seconds. Press **ENTER** within the 3 seconds if OK to complete 4 mA Output Calibration. If NOT OK, wait for first digit to flash and go to step 5 above.

20 mA Output Calibration

Note: The 20 mA output calibrates in the same fashion as 4 mA output so the 4 mA Calibration Instructions will be referenced for most of the 20 mA Calibration Instructions.

1. When **ENTER** is pressed to complete the calibration for 4 mA output, the green LED labeled "20" illuminates indicating the flashing display is the value at which the meter will produce a 20 mA output.
2. Repeat steps 2-8 in 4 mA Output Calibration above.
3. Upon acceptance of the display corresponding to the 20 mA output, the meter exits the outPut routine and returns to indication mode.

Programming Confirmation

The values that have been programmed to produce the 4 and 20 mA outputs can be quickly checked to make sure they are the desired values. To do this, enter the **outPut** routine by pressing **ENTER** and then pressing **ENTER** again when **outPut** appears.

The green "4" LED illuminates indicating the meter is displaying the value at which it will produce a 4 mA output. Confirm that this is the desired value. Press **ENTER** (within 3 seconds) before the entire display stops flashing and the green "20" LED illuminates indicating the meter is displaying the value at which it will produce a 20 mA output. Confirm that this is the desired value. Press **ENTER** (within 3 seconds) before the entire display stops flashing and the meter returns to indication mode.

LOCKOUT

Install jumper JP2 at rear of instrument to restrict modification of calibration values. When **ENTER** is pressed with lockout jumper in place, only **RLRS** and **outPut** routines are displayed. These routines may be entered to view their settings, but the settings may not be altered.

OPTIONS CARD REMOVAL & INSTALLATION

Meter options are installed at the factory. To disable relays' fail-safe operation, it is necessary to remove the Boards from the case. Refer to the following instructions and illustrations.



Disconnect power prior to performing the following operations.

The meter's snap-off cover is held in place by 6 latches that snap into notches on the snap-off cover. To remove the snap-off cover from the meter, grasp it firmly on its top and bottom edges and pull it forward. The latch plate remains around the meter's case.

To remove the circuit boards from the case:

1. Unscrew the retaining screws holding the circuit boards to the case.
2. Remove the screw terminal connectors at the rear of the meter.
3. Push the boards through the case by applying pressure to the circuit boards at the rear of the meter. Apply pressure evenly to both boards.
4. Do not apply pressure to the vertical display board.

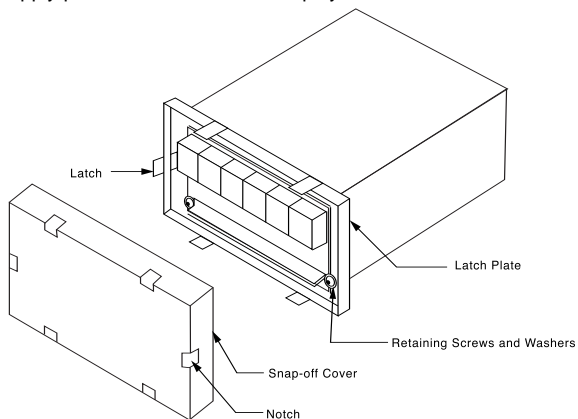

Front Cover Removal

5. Configure fail-safe jumper on Options Board as required. Remove J2 jumper to disable fail-safe operation.
6. To avoid electric shock, re-install the circuit boards in the case prior to applying power.

All programming and calibrating can be performed with the circuit boards installed in the case.

To re-install the meter in its case:

1. Fold the Options Board over the Main Board, grasp both boards so the Main Board is on the bottom and the two Boards are separated by about an inch.
2. Insert the two boards together into the case. Be sure both the top and bottom boards engage the rails, which hold them in place.
3. Do not press on the Display Board when seating the assembly in the case.
4. Install washers and retaining screws in 4 corners of meter and install front cover.

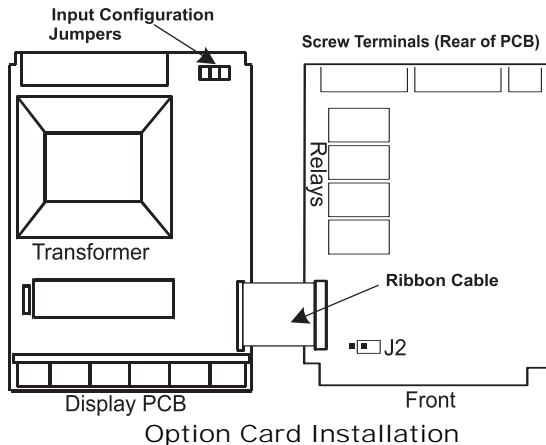

MOUNTING DIMENSIONS

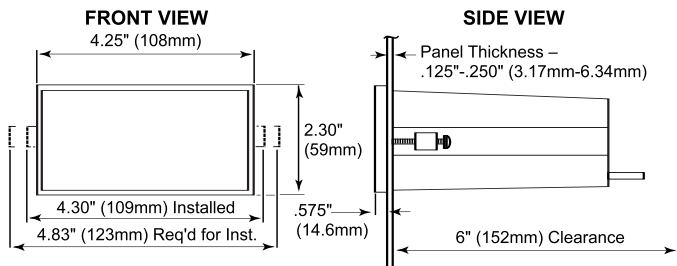

Mounting Dimensions

Notes:

1. Panel cutout required: 1.772" X 3.622" (45 mm x 92 mm) 1/8 DIN
2. Panel thickness: 0.125" - 0.250" (3.17 mm - 6.34 mm)
3. Clearance: allow 6 inches (152 mm) behind the panel

OTHER PRECISION DIGITAL PRODUCTS

| Model | Description |
|--------------|---|
| PD138 | Minimux [®] II Temperature & Process Scanner |
| PD154 | Vigilante [®] II 4-Point Annunciator (UL Listed) |
| PD158 | Vigilante [®] II 4-Point Annunciator (UL Listed) |
| PD202-253 | Digital Pressure Gauges |
| PD603 | Sabre P Low-Cost Process Meter (UL Listed) |
| PD644 | Javelin D High-Voltage DC Panel Meter |
| PD650 | 2.3" LED NEMA 4X Large Display Process Meter |
| PD655 | 1.0" LED NEMA 4X Large Display Process Meter |
| PD656 | 0.8" LED Exp-Proof Large Display Process Meter |
| PD660 | Low-Cost NEMA 4X Loop Powered Meter |
| PD661 | Low-Cost Exp-Proof Loop Powered Meter (FM & CSA) |
| PD683 | Loop-Powered Meter |
| PD684 | Loop-Powered Rate/Totalizer |
| PD685 | 3½ Digit Loop Powered NEMA 4X Meter (General Purpose) |
| PD686 | 3½ Digit Loop Powered NEMA 4X Meter (FM & CSA) |
| PD687 | 3½ Digit Loop Powered Exp-Proof Meter (FM & CSA) |
| PD688 | Loop-Powered Meter (FM & CSA) |
| PD689 | Loop-Powered Rate/Totalizer (FM & CSA) |
| PD690 | 1/8 DIN Analog Input Process Meter (UL Listed) |
| PD691 | 1/8 DIN Strain Gauge & mV Input Meter (UL Listed) |
| PD692 | 1/8 DIN Analog Input Flow Rate/Totalizer (UL Listed) |
| PD693 | 1/8 DIN Pulse Input Flow Rate/Totalizer (UL Listed) |
| PD743 | Sabre T Low-Cost Temperature Meter (UL Listed) |
| PD750 | TC & RTD Temperature Meter (UL Listed) |
| PD751-752 | 10 Ω Cu & 120 Ω Ni RTD Temperature Meters (UL Listed) |
| PD765 | Trident Process & Temperature Meter (UL Listed) |
| PD865 | Snooper Modbus Serial Input Meter |
| PD940-981 | ConsoliDator [®] Multi-Channel Controllers |
| PD6000 | PROVu Process Meter (UL Listed) |
| PD6200 | PROVu Analog Rate/Totalizer (UL Listed) |
| PD6300 | PROVu Pulse Rate/Totalizer (UL Listed) |

How to Contact Precision Digital

- For Technical Support please
Call: (800) 610-5239 or (508) 655-7300
Fax: (508) 655-8990
Email: support@predig.com
- For Sales Support or to place an order please
Call: (800) 343-1001 or (508) 655-7300
Fax: (508) 655-8990
Email: sales@predig.com
- For Calibration Services info please visit
www.predig.com
- For the latest version of this manual please visit
www.predig.com

